

TO SNAP-LOCK IN A .156±.003
[4±0.08] DIA. HOLE, IN A
.062 [1.57] PANEL THICKNESS

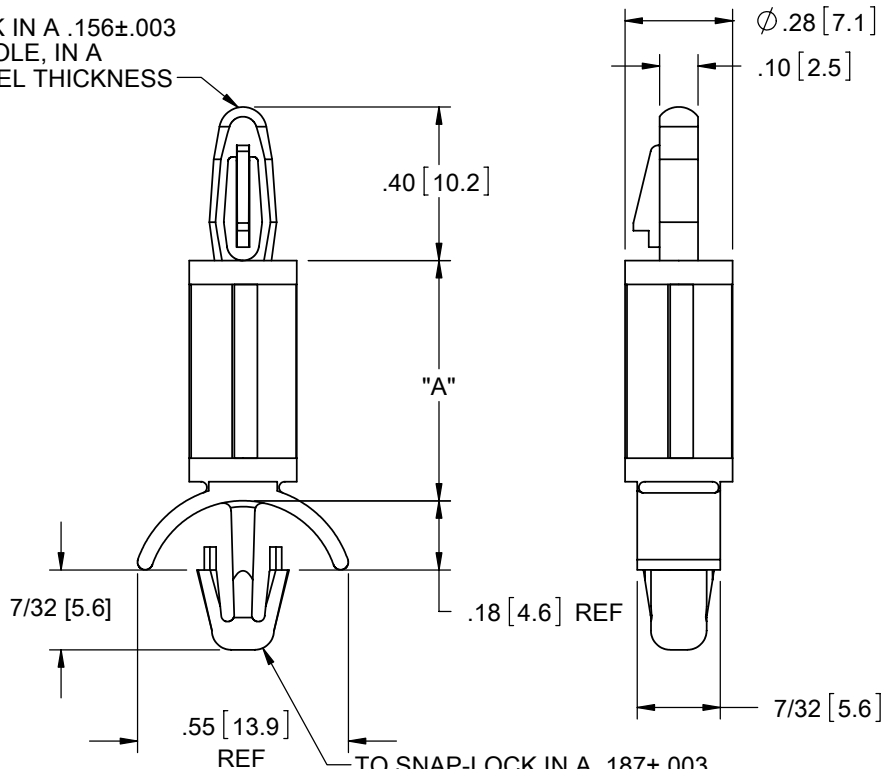

TO SNAP-LOCK IN A .187±.003
[4.75±0.08] DIA. HOLE, IN A
.078-.141 [1.98-3.58] PANEL THICKNESS

MATERIAL: NYLON 6/6 UL 94 V-2 (RMS-01) PART NO.	MATERIAL: NYLON 6/6 UL 94 V-0 (RMS-19) PART NO.	DIM. "A"±.015
LCBS-2-3-01	LCBS-2-3-19	3/16 [4.8]
LCBS-2-4-01	LCBS-2-4-19	1/4 [6.4]
LCBS-2-5-01	LCBS-2-5-19	5/16 [7.9]
LCBS-2-6-01	LCBS-2-6-19	3/8 [9.5]
LCBS-2-7-01	LCBS-2-7-19	7/16 [11.1]
LCBS-2-8-01	LCBS-2-8-19	1/2 [12.7]
LCBS-2-10-01	LCBS-2-10-19	5/8 [15.9]
LCBS-2-12-01	LCBS-2-12-19	3/4 [19.1]
LCBS-2-14-01	LCBS-2-14-19	7/8 [22.2]
LCBS-2-16-01	LCBS-2-16-19	1.0 [25.4]
LCBS-2-18-01	LCBS-2-18-19	1-1/8 [28.6]
LCBS-2-20-01	LCBS-2-20-19	1-1/4 [31.7]
LCBS-2-22-01	LCBS-2-22-19	1-3/8 [34.9]

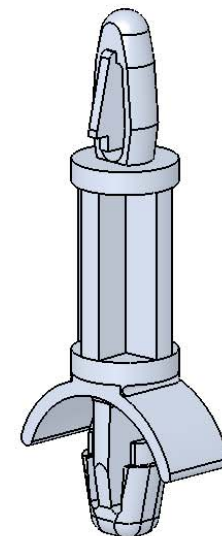

NOTES:

1. MATERIAL: NYLON 4/6, UL 94 V-2 (RMS-109), AVAILABLE BY SPECIAL ORDER ONLY. TO ORDER REPLACE "-01" WITH "-109"
2. COLOR: NATURAL
3. ALTERNATE UNITS FOR REFERENCE ONLY

E	REDRAWN, SEE ECN #1211 FOR CHANGES	SK	09/08/06
-	SEE ENG FOR REV A-D	-	----
REV.	DESCRIPTION	ENGR.	DATE

TITLE: LOCKING CIRCUIT BOARD SUPPORT, TYPE 2				DWG IN IN [mm]				
CREATED USING SOLIDWORKS TOLERANCES UNLESS NOTED .XX=±.010 .XXX=±.005 FRAC.=±1/64 ANG.=±1°		FILE #: LCBS-2	DWN: SK	APP: RT	FINAL			
RE: RICHCO, INC.		SHEET: 1 OF 1	SHEET SIZE: A	DT: 08/23/06	CHKD: SJ	PART #		
		RICHCO, INC.		ENG@RICHCO-INC.COM (773) 539-4060		SEE TABLE		PRINT TYPE CA